

THIS DRAWING IS UNPUBLISHED. RELEASED FOR PUBLICATION
 © COPYRIGHT BY TYCO ELECTRONICS CORPORATION. ALL RIGHTS RESERVED.

LOC	DIST	REVISIONS					
FT	0	P	LTR	DESCRIPTION	DATE	DWN	APVD
			D	REVISED PER ECO-08-010814	15MAY08	HMR	MZ

MATERIAL:
 HOUSING: THERMOPLASTIC, UL94V-0, BLACK.
 TERMINAL: BRIGHT TIN PLATED COPPER ALLOY.
 SCREW: 8-32, ZINC PLATED STEEL.

ELECTRICAL:
 CURRENT RATING: 30A
 VOLTAGE RATING: 600V
 WIRE RANGE: 10-18 AWG (UL)
 10-22 AWG (CSA)

MECHANICAL:
 RECOMMENDED TORQUE: 20 IN-LB
 OPERATING TEMP.: -40°C TO +120°C.

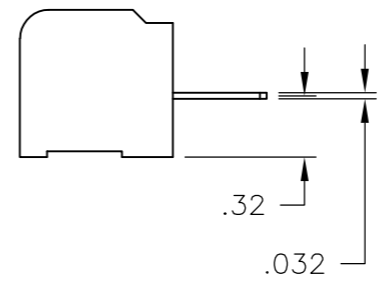
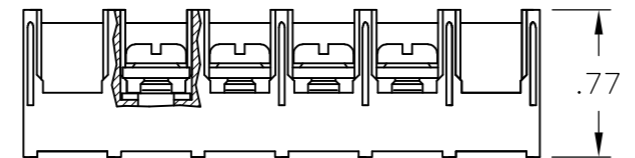
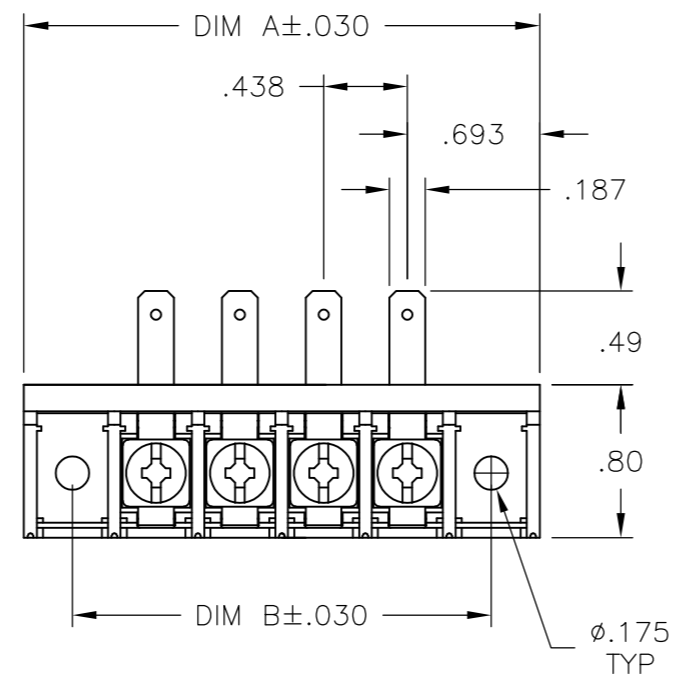

SEE FIGURE

8.750	8.823	18	8QCR-18-008	1-1546588-8
8.313	8.385	17	8QCR-17-008	1-1546588-7
7.875	7.948	16	8QCR-16-008	1-1546588-6
7.438	7.510	15	8QCR-15-008	1-1546588-5
7.000	7.073	14	8QCR-14-008	1-1546588-4
6.563	6.635	13	8QCR-13-008	1-1546588-3
6.125	6.198	12	8QCR-12-008	1-1546588-2
5.688	5.760	11	8QCR-11-008	1-1546588-1
5.250	5.323	10	8QCR-10-008	1-1546588-0
4.813	4.885	9	8QCR-09-008	1546588-9
4.375	4.448	8	8QCR-08-008	1546588-8
3.938	4.010	7	8QCR-07-008	1546588-7
3.500	3.573	6	8QCR-06-008	1546588-6
3.063	3.135	5	8QCR-05-491	9-1546159-3
2.625	3.135	5	8QCR-05-008	1546588-5
2.188	2.698	4	8QCR-04-008	1546588-4
1.750	2.260	3	8QCR-03-008	9-1546159-0
1.313	1.823	2	8QCR-02-008	8-1546159-7
DIM B	DIM A	NO OF POS	CATALOG NUMBER	TE PART NO

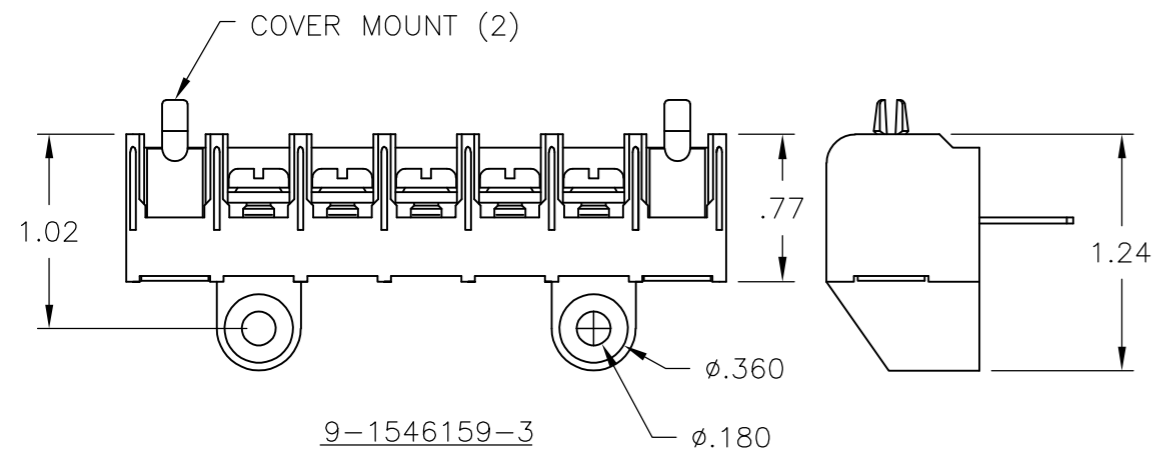

THIS DRAWING IS A CONTROLLED DOCUMENT.

DWN	S SCHLEGEL	8/18/04	Tyco Electronics Corporation Harrisburg, PA 17105-3608
CHK	S YODER	8/18/04	
APVD	S YODER	8/18/04	
PRODUCT SPEC	NAME		
APPLICATION SPEC	8QCR-XX-008 ASSEMBLY		RESTRICTED TO
WEIGHT	A3 00779 C-8-1546159-7		
CUSTOMER DRAWING			SCALE 1:1 SHEET 1 OF 1 REV D